



Martini Nautica

Design Pedalboats

www.martininautica.com





Qualità e sicurezza garantite da mezzo secolo di attività

Quality and safety are granted since half a century

 Qualità e sicurezza garantite da mezzo secolo di attività

Un binomio che vale sia per i nostri prodotti, sia per gli ambienti di lavoro che rispettano gli standard imposti e la natura. Utilizziamo materie riciclabili ed ecologiche e ci sottoponiamo a verifiche periodiche.

 Almost half a century of top quality and safety. Quality and safety are at the heart of what we do. Both our product and our workplace comply with all the safety and environmental standards.

We use recyclable and ecological materials and do run periodical tests.

 Qualité et sécurité
Un binôme qui caractérise nos produits, mais aussi le milieu de travail, chez Martini on respecte les standards de sécurité mais aussi la nature. On utilise des matériaux recyclables et écologiques et on est soumis à des contrôles périodiques.

 Qualität und Sicherheit
Beides gilt für unsere Produkte, sowohl als auch für den Arbeitsplatz, die die vorgegebenen Standards und die Natur berücksichtigen. Wir benutzen wiederverwertbare und umweltfreundliche Materialien und führen regelmäßig Tests durch.



Tradizione e Innovazione / *Tradition and Innovation*



Martini Costruzioni Nautiche è un'azienda

familiare, esempio del famoso artigianato italiano. Fu fondata da mio padre quasi mezzo secolo fa e da allora portiamo avanti la filosofia del lavoro fatto a mano e del design Made in Italy.

La linea SUNNY® viene prodotta interamente nel nostro stabilimento. Seguiamo il processo produttivo in tutte le fasi, mettendo a frutto la nostra esperienza e la nostra creatività.

Questa particolare cura del dettaglio rende i nostri natanti unici e di altissima qualità. Il nostro è un prodotto resistente, sicuro e di design.



Martini Costruzioni Nautiche is a

family-owned company and is an example of fine Italian craftsmanship. My father founded it almost half a century ago and since then we've been keeping with our philosophy of creating handmade Italian design products.

The SUNNY® line is entirely produced in our workshop. We oversee directly all the steps of production making the most of our experience and creativity. Our careful attention to detail makes our boats unique and of the highest quality. Our product is resistant, safe and stylish.



Fondatore della Martini Costruzioni Nautiche.
Ireneo Martini (foto d'epoca)



Martini Costruzioni Nautiche est une

entreprise familiale qui représente encore la célèbre tradition artisanale italienne. Elle a été fondée par mon père, il y a environ un demi-siècle. Notre philosophie est toujours la même : le travail est fait à la main, le produit est conçu et fabriqué en Italie. La ligne SUNNY® est entièrement produite dans notre usine. On suit toutes les phases de la production, en mettant en valeur notre expérience et notre créativité.

Cette attention spéciale pour les détails rend nos embarcations uniques et d'une très grande qualité. Notre produit est résistant, sûr et élégant.



Innovation aus Tradition
Die Martini Costruzioni Nautiche ist ein

Familienunternehmen und Ausdruck des italienischen Handwerks. Das Unternehmen wurde vor fast einem halben Jahrhundert von meinen Vater gegründet und seit dem führen wir die Tradition des Handwerks und des Made in Italy Design fort.

Die Produktion der Serie "Sunny" erfolgt komplett in unserer Werkstatt, wo wir jeden einzelnen Schritt pflegen und unsere Erfahrung und Kreativität einsetzen.

Dank dieser Liebe zum Detail sind unsere Boote unvergleichlich und aus bester Qualität. Unser Endprodukt ist strapazierfähig, sicher und stilvoll.



SUNNY® la famosa linea di natanti a pedali, con tanti modelli e accessori per tutte le esigenze

 I nostri modelli soddisfano tutte le esigenze e tutti i gusti. Ogni modello è personalizzabile grazie a una vasta gamma di accessori. Il cliente ha la possibilità di farsi confezionare il suo prodotto su misura.

Il criterio di qualità si evidenzia anche nell'attenzione per la sicurezza. Ogni natante ha al suo interno una riserva di galleggiamento a garantire l'inaffondabilità anche nel caso improbabile di rottura dello scafo. La robustezza e la resistenza che caratterizza i nostri natanti, li rendono ideali per l'utilizzo commerciale e il noleggio.

Dove c'è acqua, c'è Martini!

 We have a variety of models to suit all needs and tastes. All our boats are customizable with our wide range of accessories. The client can choose how to configure his boat. Our focus on quality is also aimed at ensuring top notch safety. Each boat is equipped with a floating device that makes it unsinkable, even in case hull breaks.

Our boats are suitable for commercial use and for rental, because they are solid and strong.

Where there is water, there is Martini!

 Une grande variété de modèles pour tous les goûts et exigences. Chaque modèle est personnalisable grâce à une vaste gamme d'accessoires. Le client a la possibilité de demander la réalisation d'un produit sur mesure.

La qualité de nos produits passe aussi par la grande attention qu'on porte à la sécurité. Chaque embarcation affiche une réserve de flottaison pour assurer l'insubmersibilité même dans le cas improbable de rupture de la coque.

La solidité et la résistance, caractérisant nos embarcations, en font des produits idéaux pour l'utilisation commerciale et la location.

Là où il y a de l'eau, il y a Martini!

 Unsere Modelle erfüllen alle Bedürfnisse und jeden Geschmack. Dank des Zubehörs kann jedes Modell persönlich gestaltet werden. Das Produkt wird auf die Wünsche des Kunden angepasst. Unsere Qualität spiegelt sich auch in der Aufmerksamkeit für die Sicherheit wieder. Jedes Boot ist mit Auftriebskörper ausgestattet und daher unsinkbar, auch im Falle eines Rumpfbruchs.

Robuste und strapazierfähige Boote die ideal für den gewerblichen Gebrauch und den Verleih sind.

Wasser ruft Martini!



MARTINI il tuo mare di emozioni

I nostri punti di forza sono:

- ★ Grande varietà di modelli per utilizzo commerciale e privato
- ★ Lavorazione artigianale
- ★ Design inconfondibile
- ★ 100% Made in Italy
- ★ Sicurezza
- ★ Garanzia 24 mesi

Our strengths are:

- ★ A wide range of products, suitable for commercial and private use
- ★ Craftsmanship
- ★ Unique design
- ★ 100% Made in Italy
- ★ Safety
- ★ A 24 month guarantee

Nos points de force sont :

- ★ Une grande variété de modèles pour utilisation commerciale et privée
- ★ Travail artisanal
- ★ Conception inimitable
- ★ 100% Produit en Italie
- ★ Sécurité
- ★ Garantie 24 mois

Unsere Stärken sind:

- ★ Vielfalt der Modelle für den gewerblichen und privaten Gebrauch
- ★ Handwerkliche Bearbeitung
- ★ Unverwechselbares Design
- ★ 100% Made in Italy
- ★ Sicherheit
- ★ 24 Monate Garantie





DRAGO.....	Pg. 8	ULISSE	Pg. 49
FLAMINGO	Pg. 10	PEDAL-E.....	Pg. 50
CIGNO	Pg. 12	VERSAILLES.....	Pg. 52
UNICORNO.....	Pg. 14	REDLIFE	Pg. 55
ANATRA	Pg. 16	HYBRID RESCUE	Pg. 56
SUNNY H2O	Pg. 18	BAYLIFE	Pg. 58
SUNNY H2O PLUS	Pg. 20	VIAREGGIO RESCUE.....	Pg. 59
SUNNY H2O SMART	Pg. 22	TORRETTA LIFEGUARD COLOMBO.....	Pg. 60
JOLIE	Pg. 24	VIAREGGIO RELAX.....	Pg. 62
HAPPY HOUR.....	Pg. 26	PARADISE	Pg. 63
SUNNY TIME 4	Pg. 28	GRETA.....	Pg. 64
SUNNY TIME S.....	Pg. 30	GRETA EVO	Pg. 65
SUNNY TIME SPECIAL.....	Pg. 32	MALIBU	Pg. 66
SUNNY MOUSE.....	Pg. 34	NIRVANA	Pg. 67
SUNNY TIME 330	Pg. 36	AKITA.....	Pg. 68
SEABUGGY 405	Pg. 38	AKITA DOUBLE.....	Pg. 69
SEABUGGY 330	Pg. 40	PEGASO K1	Pg. 70
SUNNY R	Pg. 42	MOOREA 123	Pg. 71
SUNNY SPEEDY	Pg. 43	ACCESSORI PER CANOE E RESCUE.....	Pg. 72
SUNNY SPEEDY 4	Pg. 44	PEDAL BOATS SPARE PARTS	Pg. 73
SPEEDY + MANOLO'.....	Pg. 45	COLORI PER FIBRA DI VETRA.....	Pg. 74
OPTIONAL	Pg. 46	COLORI PER POLIETILENE	Pg. 75
		DISTRIBUTORI.....	Pg. 76



DRAGO



Siamo partiti dal nostro campione di vendite e gli abbiamo conferito un look bestiale. La garanzia Martini Nautica si conferma in nuova veste. Corpo interamente rielaborato, forme armoniose e un elegante collo. Spazio ideale per la famiglia o un gruppo di amici. Il divertimento sull'acqua è garantito. Il design si rinnova, conservando tutte le caratteristiche di robustezza, sicurezza e agilità.



We gave our all-time bestseller a beastly look. One of Martini's highest-quality creations comes in a new version. The body has been entirely reworked and now has new harmonious shapes and an elegant swan neck. It's perfect for having fun in the water with your family or a group of friends! The design is brand new while the boat's safety, sturdiness and agility remain unchanged.



OPTIONAL

- 03 Protezione chiglia/Keel protection
- 04/Y Scaletta/Ladder Yacht
- 04/B Scaletta/Ladder Basic
- 04/E Scaletta/Ladder Elite
- 06 Ruote / Wheels
- 07 Scivolo/Slide
- 11 Buffer

DOTAZIONE DI SERIE STANDARD EQUIPMENT

- 05 Parabordo/Rubber fender

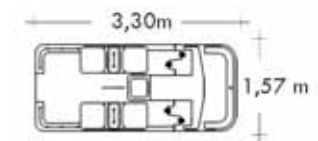

4 + = 300 kg WEIGHT 145 kg
MATERIAL: FIBERGLASS





FLAMINGO

Essere Rosa
Be Pink



OPTIONAL

- 03 Protezione chiglia/Keel protection
- 04/Y Scaletta/Ladder Yacht
- 04/B Scaletta/Ladder Basic
- 04/E Scaletta/Ladder Elite
- 06 Ruote / Wheels
- 07 Scivolo/Slide
- 11 Buffer

DOTAZIONE DI SERIE STANDARD EQUIPMENT

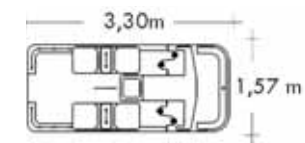
- 05 Parabordo/Rubber fender



4  +  = 300 kg WEIGHT 145 kg
MATERIAL: FIBERGLASS





CIGNO

OPTIONAL



- 03 Protezione chiglia/Keel protection
- 04/Y Scaletta/Ladder Yacht
- 04/B Scaletta/Ladder Basic
- 04/E Scaletta/Ladder Elite
- 06 Ruote / Wheels
- 07 Scivolo/Slide
- 11 Buffer

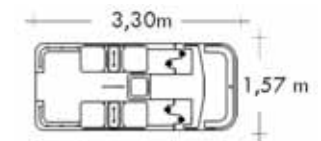

DOTAZIONE DI SERIE STANDARD EQUIPMENT

- 05 Parabordo/Rubber fender



4  +  = 300 kg WEIGHT 145 kg
MATERIAL: FIBERGLASS



UNICORNO

Momenti Magici *Magic Moments*

OPTIONAL

03 Protezione chiglia/Keel protection

04/Y Scaletta/Ladder Yacht

04/B Scaletta/Ladder Basic

04/E Scaletta/Ladder Elite

06 Ruote / Wheels

07 Scivolo/Slide

11 Buffer

DOTAZIONE DI SERIE STANDARD EQUIPMENT

05 Parabordo/Rubber fender

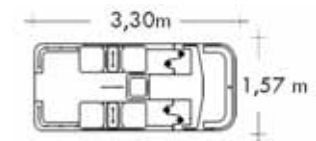

4 + = 300 kg WEIGHT 145 kg
MATERIAL: FIBERGLASS





ANATRA

◀ Lucky Duck

OPTIONAL

- 03 Protezione chiglia/Keel protection
- 04/Y Scaletta/Ladder Yacht
- 04/B Scaletta/Ladder Basic
- 04/E Scaletta/Ladder Elite
- 06 Ruote/Wheels
- 07 Scivolo/Slide
- 11 Buffer



DOTAZIONE DI SERIE STANDARD EQUIPMENT

- 05 Parabordo/Rubber fender

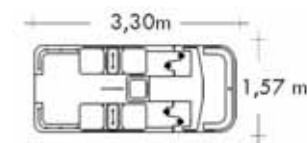

◀ Duckling



4  +  = 300 kg WEIGHT 145 kg
MATERIAL: FIBERGLASS





SUNNY H2O

OPTIONAL

04/B Scaletta/Ladder Basic

04/E Scaletta/Ladder Elite

06 Ruote/Wheels

07 Scivolo/Slide

11 Buffer

15 Telo di rimessaggio/Textile coverage

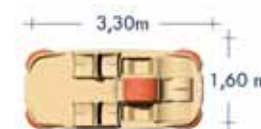
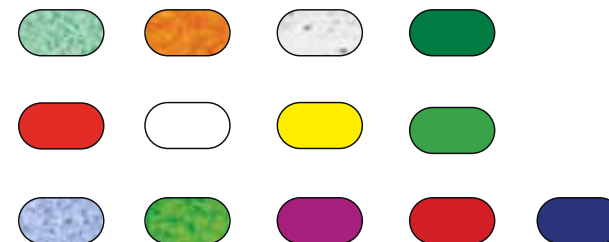

4 + = 300 kg WEIGHT 130 kg
MATERIAL: POLYETHYLENE





SUNNY H2O PLUS

OPTIONAL

- 04/B Scaletta/Ladder Basic
- 04/E Scaletta/Ladder Elite
- 06 Ruote/Wheels
- 07 Scivolo/Slide Maxi
- 11 Buffer
- 15 Telo di rimessaggio/Textile coverage

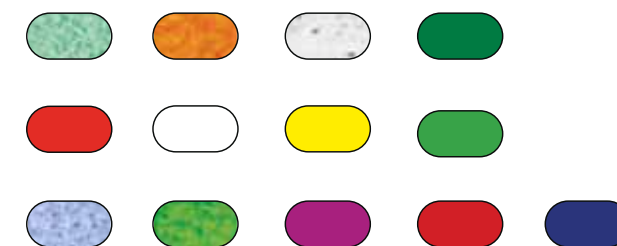

5 + = 375 kg WEIGHT 150 kg
MATERIAL: POLYETHYLENE



Lido di Lugana

1661 BS D

SUNNY

13

MARTINI

H2O 25

H2O 25



SUNNY H2O SMART

OPTIONAL

- 04/B Scaletta/Ladder Basic
- 04/E Scaletta/Ladder Elite
- 06 Ruote/Wheels
- 07 Scivolo/Slide
- 11 Buffer
- 15 Telo di rimessaggio/Textile coverage

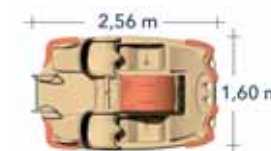
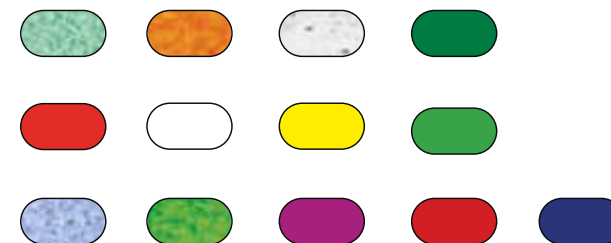

2 + 2 + = 225 kg WEIGHT 90 kg
MATERIAL: POLYETHYLENE





JOLIE

OPTIONAL

- 03 Protezione chiglia/Keel protection
- 04/Y Scaletta/Ladder Yacht
- 04/B Scaletta/Ladder Basic
- 04/E Scaletta/Ladder Elite
- 06/J Ruote d'alaggio mod. Jolie
Haulage wheels mod. Jolie
- 09 Tettuccio parasole/Sun&rain shield
- 10 Trampolino/Spring board
- 11 Buffer
- 12/S Scivolo/Slide Superslider
- 15 Telo di rimessaggio
Textile coverage

DOTAZIONE DI SERIE STANDARD EQUIPMENT

- 05 Parabordo/Rubber fender

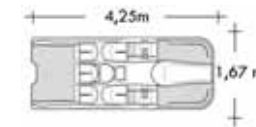
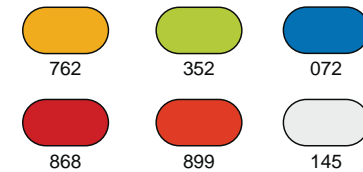

6 + = 450 kg WEIGHT 170 kg
MATERIAL: FIBERGLASS





HAPPY HOUR

OPTIONAL

- 03 Protezione chiglia/Keel protection
- 04/B Scaletta/Ladder Basic
- 04/E Scaletta/Ladder Elite
- 06 Ruote/Wheels
- 09 Tettuccio parasole/Sun&rain shield
- 10 Trampolino/Spring board
- 11 Buffer
- 15 Telo di rimessaggio/Textile coverage
- Borsa Termica

DOTAZIONE DI SERIE STANDARD EQUIPMENT

- 02 Pulpito/Bow pulpit
- 05 Parabordo/Rubber fender

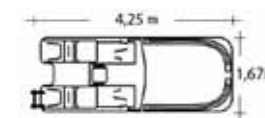
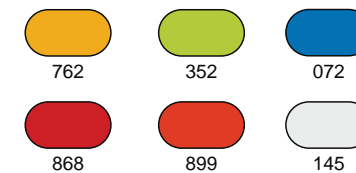

5 + = 375 kg WEIGHT 170 kg
MATERIAL: FIBERGLASS





Happy Hour

SUNNY TIME 4

OPTIONAL

- 02 Pulpito/Bow pulpit
- 03 Protezione chiglia/Keel protection
- 04 Scaletta/Ladder Standard
- 04/Y Scaletta/Ladder Yacht
- 04/B Scaletta/Ladder Basic
- 04/E Scaletta/Ladder Elite
- 05 Parabordo/Rubber fender
- 06 Ruote/Wheels
- 07 Scivolo/Slide
- 09 Tettuccio parasole/Sun&rain shield
- 10 Trampolino/Spring board
- 11 Buffer
- 12/B Scivolo/Slide Big Slider
- 12/S Scivolo/Slide Superslider
- 13 Scivolo/Slide Bent-slider
- 15 Telo di rimessaggio/Textile coverage

DOTAZIONE DI SERIE STANDARD EQUIPMENT

- 01 Maniglie tieniti bene/Handle

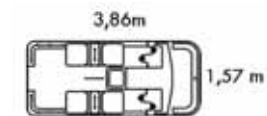
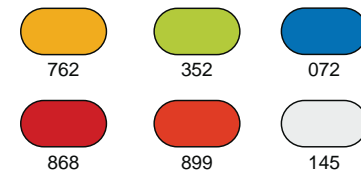

5 + = 375 kg WEIGHT 150 kg
MATERIAL: FIBERGLASS





SUNNY TIME S

OPTIONAL

- 02 Pulpito/Bow pulpit
- 03 Protezione chiglia/Keel protection
- 04 Scaletta/Ladder Standard
- 04/Y Scaletta/Ladder Yacht
- 04/B Scaletta/Ladder Basic
- 04/E Scaletta/Ladder Elite
- 05 Parabordo/Rubber fender
- 06 Ruote/Wheels
- 07 Scivolo/Slide
- 09 Tettuccio parasole/Sun&rain shield
- 10 Trampolino/Spring board
- 11 Buffer
- 12/B Scivolo/Slide Big Slider
- 12/S Scivolo/Slide Superslider
- 13 Scivolo/Slide Bent-slider
- 15 Telo di rimessaggio/Textile coverage



DOTAZIONE DI SERIE STANDARD EQUIPMENT

- 01 Maniglie tieniti bene/Handle

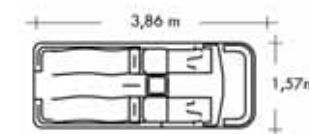
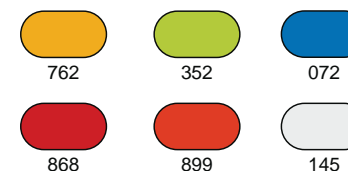

5 + = 375 kg WEIGHT 150 kg
MATERIAL: FIBERGLASS





SUNNY TIME SPECIAL

OPTIONAL

- 02 Pulpito/Bow pulpit
- 03 Protezione chiglia/Keel protection
- 04 Scaletta/Ladder Standard
- 04/Y Scaletta/Ladder Yacht
- 04/B Scaletta/Ladder Basic
- 04/E Scaletta/Ladder Elite
- 05 Parabordo/Rubber fender
- 06 Ruote/Wheels
- 07 Scivolo/Slide
- 09 Tettuccio parasole/Sun&rain shield
- 10 Trampolino/Spring board
- 11 Buffer
- 12/B Scivolo/Slide Big Slider
- 12/S Scivolo/Slide Superslider
- 13 Scivolo/Slide Bent-slider
- 15 Telo di rimessaggio/Textile coverage

DOTAZIONE DI SERIE STANDARD EQUIPMENT

- 01 Maniglie tieniti bene/Handle

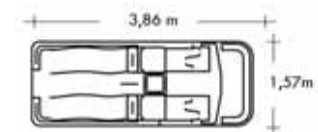
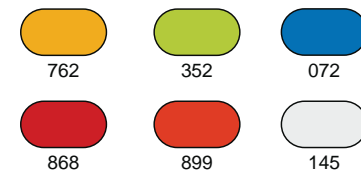

5 + = 375 kg WEIGHT 150 kg

MATERIAL: FIBERGLASS







SUNNY MOUSE

OPTIONAL

05 Parabordo/Rubber fender

11 Buffer

15 Telo di rimessaggio/Textile coverage

DOTAZIONE DI SERIE

STANDARD EQUIPMENT

01 Maniglie tieniti bene/Handle

03 Protezione chiglia/Keel protection

04/Y Scaletta/Ladder Yacht

06 Ruote/Wheels

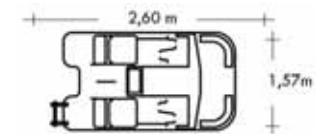
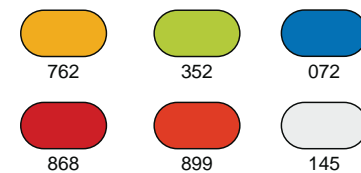

3 + = 225 kg WEIGHT 100 kg

MATERIAL: FIBERGLASS





SUNNY TIME 330

OPTIONAL

- 02 Pulpito/Bow pulpit
- 03 Protezione chiglia/Keel protection
- 04 Scaletta standard/Standard Ladder
- 04/Y Scaletta/Ladder Yacht
- 04/B Scaletta/Ladder Basic
- 04/E Scaletta/Ladder Elite
- 05 Parabordo/Rubber fender
- 06 Ruote/Wheels
- 07 Scivolo/Slide
- 09 Tettuccio parasole/Sun&rain shield
- 10 Trampolino/Spring board
- 11 Buffer
- 15 Telo di rimessaggio/Textile coverage

DOTAZIONE DI SERIE STANDARD EQUIPMENT

- 01 Maniglie tieniti bene/Handle

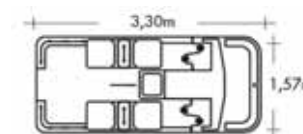
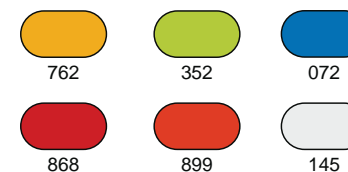

4 + = 300 kg WEIGHT 120 kg
MATERIAL: FIBERGLASS





SEABUGGY 405

OPTIONAL

- 03 Protezione chiglia/Keel protection
- 10 Trampolino/Spring board
- 11 Buffer
- 12/S Scivolo/Slide Superslider
- 15 Telo di rimessaggio/Textile coverage
- SB Capottina alluminio con tessuto
Alu-sunshield with fabric

DOTAZIONE DI SERIE STANDARD EQUIPMENT

- 04/E Scaletta/Ladder Elite
- 05 Parabordo/Rubber fender
- 06 Ruote/Wheels

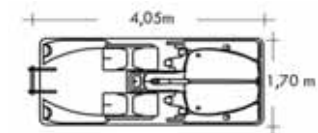
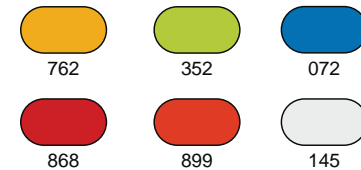

5 + = 400 kg WEIGHT 160 kg
MATERIAL: FIBERGLASS







SEABUGGY 330

OPTIONAL

- 03 Protezione chiglia/Keel protection
- 04/B Scaletta/Ladder Basic
- 04/E Scaletta/Ladder Elite
- 05 Parabordo/Rubber fender
- 06 Ruote/Wheels
- 10 Trampolino/Spring board
- 11 Buffer
- 15 Telo di rimessaggio/Textile coverage
- SB Capottina alluminio con tessuto
Alu-sunshield with fabric

DOTAZIONE DI SERIE STANDARD EQUIPMENT

- 04/Y Scaletta/Ladder Yacht
- 05 Parabordo/Rubber fender

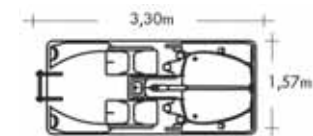
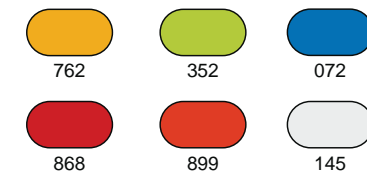

4 + = 300 kg WEIGHT 140 kg
MATERIAL: FIBERGLASS



Ideale per prendere il sole
Ideal for sunbathing



SUNNY R

OPTIONAL

- 03 Protezione chiglia/Keel protection
- 04/B Scaletta/Ladder Basic
- 04/E Scaletta/Ladder Elite
- 05 Parabordo/Rubber fender
- 06 Ruote/Wheels
- 07 Scivolo/Slide
- 09 Tettuccio parasole/Sun&rain shield
- 10 Trampolino/Spring board
- 11 Buffer
- 12/B Scivolo/Slide Big Slider
- 15 Telo di rimessaggio/Textile coverage

DOTAZIONE DI SERIE

STANDARD EQUIPMENT

- 01 Maniglie tieniti bene/Handle
- 02 Pulpito/Bow pulpit
- 04/Y Scaletta/Ladder Yacht



762



352



072



868



899





145

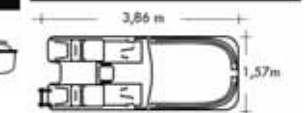
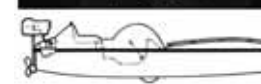

SUNNY R/FB  = 1,47 Kw  5+ = 375 kg CAT. D



5  +  = 375 kg WEIGHT 150 kg
MATERIAL: FIBERGLASS

SUNNY SPEEDY

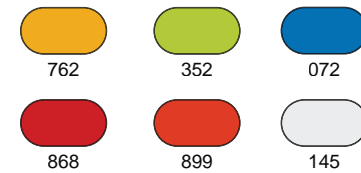

OPTIONAL

03 Protezione chiglia/Keel protection
15 Telo di rimessaggio/Textile coverage

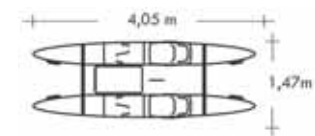

Un lungo piacere - veloce e leggero per percorrere distanze
Fast and slim - for long distances



2  +  = 200 kg WEIGHT 100 kg
MATERIAL: FIBERGLASS



SUNNY SPEEDY 4



OPTIONAL

03 Protezione chiglia/Keel protection
15 Telo di rimessaggio/Textile coverage



762



352



072



868





899

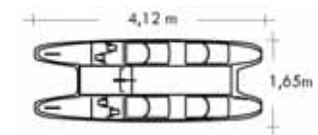

145



4  +  = 300 kg WEIGHT 130 kg
MATERIAL: FIBERGLASS

Il dispositivo per la "pedalata manuale" brevettato. Divertimento, sport e tempo libero accessibili a tutti.
Our patented device for "manual pedaling". Fun, sports and leisure for really everyone.



SPEEDY + MANOLO'

 Il dispositivo per la "pedalata manuale" brevettato. Divertimento, sport e tempo libero accessibili a tutti.

Sport, divertimento e mare accessibili a tutti! Questo particolare dispositivo da noi brevettato permette di trasmettere la forza motrice anche o addirittura solo con le braccia. Perfetta per lo sport all'area aperta e per competizioni sportive!



 Our patented device for "hand pedaling". Fun and leisure accessible for everyone.

Making sports, fun and the sea accessible to everyone! With our patented device, the boat can be also or exclusively arm – propelled. Perfect for outdoor sports and competitions!

OPTIONAL

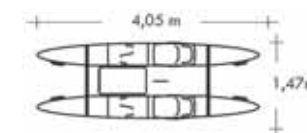
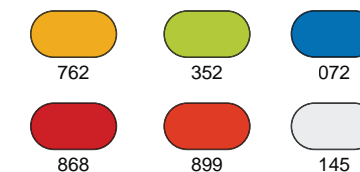
- 03 Protezione chiglia/Keel protection
- 15 Telo di rimessaggio/Textile coverage



2  +  = 200 kg WEIGHT 100 kg
 MATERIAL: FIBERGLASS

OPTIONAL



01
Maniglie
tieniti bene
Handle



02
Pulpito
Bow pulpit



03
Protezione chiglia
Keel protection



04
Scaletta
standard
*Standard
Ladder*



04/Y
Scaletta
Ladder Yacht



04/B
Scaletta
Ladder Basic

04/E
Scaletta
Ladder Elite



05
Parabordo
Rubber fender



06
Ruote
Wheels

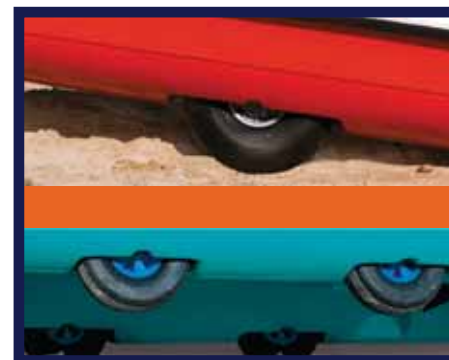

06/J
Ruote
Wheels Jumbo

06/2
4 Ruote
4 Wheels

OPTIONAL



07
Scivolo standard
Slide standard



08
Salvagente
anulare
Life buoy



09
Tettuccio parasole
Sun&rain shield



10
Trampolino
Spring board



11
Buffer
Buffer



12/B
Scivolo
Big Slider



12/S
Scivolo
Slide Superslider



13
Scivolo
Bent Slider



15
Telo di rimessaggio
Textile coverage



ULISSE

OPTIONAL

07 Scivolo/Slide

10 Trampolino/Spring board

11 Buffer

DOTAZIONE DI SERIE STANDARD EQUIPMENT

04/B Scaletta/Ladder Basic

05 Parabordo/Rubber fender

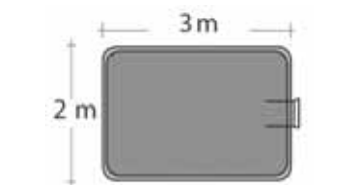
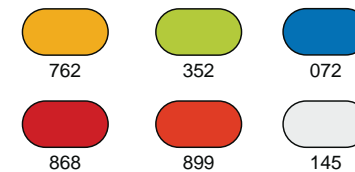

WEIGHT 150 kg
MATERIAL: FIBERGLASS

PEDAL – E

ELECTRIC PEDAL BOAT

PEDAL-E: L'Innovazione che rivoluziona il giro in pedalò

Il PEDAL-E incarna la rivoluzione dei dispositivi a pedali, rendendo ogni uscita accessibile a tutti, anche a chi non è particolarmente allenato. Grazie alla sua avanzata assistenza elettrica, trasforma ogni avventura in un'esperienza rilassante, ideale per esplorare senza fatica.

PEDAL-E rivoluziona l'uso del pedalò tradizionale, permettendoti di fare molto più di una semplice gita per fare il bagno. Con PEDAL-E puoi vivere escursioni più lunghe lungo la costa e rilassanti passeggiate su laghi, fiumi e canali. Perfetto per ogni ambiente, è l'opzione ideale per il turismo, trasformando ogni luogo, dal mare ai bacini interni, in un'esperienza indimenticabile.

Specifiche Tecniche

MOTORE

Motore brushless da 48V e 250W, sviluppato su misura da un'azienda italiana leader del settore.

ENERGY BOX

Valigetta ermetica contenente:

- Batteria al litio da 48V e 20A
- Presa per la ricarica

RICARICA

Caricabatterie con spina dedicata, facile da collegare alla presa sulla valigetta.

CONTROLLER

Discreto e posizionato all'interno per un design pulito.

AUTONOMIA

Il motore ad alte prestazioni e la batteria di ultima generazione garantiscono fino a 6 ore di utilizzo continuo, per prestazioni senza compromessi.

Prestazioni Senza Fatica

Con PEDAL-E raggiungi la velocità di una pedalata tradizionale, ma senza sforzo. Goditi il movimento, mentre l'assistenza elettrica fa tutto il lavoro per te!

Manutenzione Semplice

Oltre alla classica manutenzione di un pedalò, con PEDAL-E ti basterà ricaricare la batteria per avere prestazioni al top con il minimo impegno.

Sicurezza Garantita

PEDAL-E ti offre la scelta tra pedalata tradizionale o assistita, proprio come su una e-bike. Per attivare l'assistenza elettrica, basta posizionare i piedi sui pedali e impugnare la barra del timone dove è situato il sensore di presenza. Se non rileva l'utente, l'assistenza si disattiva automaticamente, garantendo massima sicurezza anche durante attività come relax, pesca o nuoto.

PEDAL-E: La Tua Prossima Avventura, Senza Limiti!

PEDAL-E: Redefining the Pedalo Experience

PEDAL-E ushers in a new era for pedal-powered devices, making leisurely tours accessible to everyone, including those less sporty. Its advanced electric assistance transforms each ride into a smooth, effortless journey ideal for exploration and relaxation.

PEDAL-E takes the classic pedalo beyond mere water play. It enables longer coastal excursions and serene rides on lakes, rivers, and canals. Perfect for any setting, it enhances the tourism experience, turning every destination—from seaside to inland waters—into a memorable adventure.

Technical Specifications

MOTOR

48V and 250W brushless motor, custom-designed by a top Italian manufacturer

ENERGY BOX

Watertight case with:

- 48V and 20A lithium battery
- Charging socket

CHARGE

Charger with a dedicated plug, easily connects to the energy box socket.

CONTROLLER

Integrated and discreet, designed for a sleek look.

RUNTIME

The high-performance motor and cutting-edge battery deliver up to 6 hours of continuous use, ensuring exceptional performance.

Effortless Performance

Achieve the speed of traditional pedalling without the physical strain. Enjoy the ride while the electric assistance handles the effort!

Simple Maintenance

Beyond routine pedalo maintenance, PEDAL-E requires only battery recharging to maintain peak performance effortlessly.

Safety Assure

PEDAL-E offers both traditional and assisted pedalling options, similar to an e-bike. Electric assistance activates when your feet are on the pedals and your hands on the helm bar's sensor. If the sensor does not detect the user, assistance is automatically deactivated, ensuring safety during relaxation, fishing, or swimming.

PEDAL-E: Adventure Awaits Without Limits!





VERSAILLES

Occhiello a poppa diametro 12

Ringbolt in the bow diameter 12

Scalmiera in ottone inossidabili

oarlock of Stainless brass

Protezione chiglia a prua acciaio inox

Keel protection in the bow

4 corrimano in acciaio inox

4 stainless steel handrails

Panca reversibile per ripostiglio

Swinging bench for the boat storage



762



352



072



868



899



145

VERSIONE A MOTORE

F.B.  = 4,4 Kw (6Cv)

4  +  = 320 kg

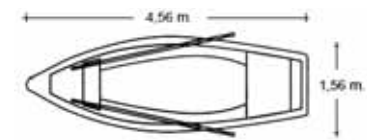

4  +  = 320 kg WEIGHT 165 kg

CAT. C





LIFEGUARD

BAGNINO

BAGNINO

SALVATAGGIO

SALVATAGGIO

Un pezzo unico
One of a kind



REDLIFE

 È il primo pattino della MARTINI Costruzioni Nautiche, interamente costruito in vetroresina con rinforzi interni al braccio della scalmiera in mogano, per essere sempre più resistente e duraturo. Molto stabile, è ideale per le operazioni di soccorso e vigilanza anche in condizioni di mare critiche. Scalmiera in ottone e acciaio inox 316 (brevettata).

È dotato di serie di ruote d'alaggio incorporate negli scafi per partire da riva velocemente, di 2 salvagenti anulari, sagola galleggiante da 30 m, 1 mezzo marinaio, 1 salvagente Baywatch. Riserva di galleggiamento in polistirene più poliuretano espanso, 2 remi in legno, manicotto in nylon per la protezione del remo (brevettato).

 REDLIFE is the first MARTINI rescue rowing catamaran entirely made of fiberglass with internal mahogany reinforcement in the sleeves of the rowlock support that makes it last longer. Very stable, it has been designed specifically for rescue operation even in critical sea conditions. It is equipped with patented rowlock in brass and stainless steel. Reserve buoyancy in polyurethane plus polystyrene foam. The incorporated haulage wheels make it easier to leave quickly the shore. Its standard equipment includes 2 ring life buoys plus 1 lifeguard rescue can, 30 m of floating rope, and one boat hook, 2 wooden oars with protective nylon muffs (patented).

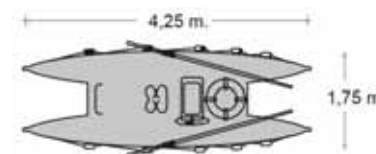

2  + 1  +  = 190 kg CAT. D

HYBRID RESCUE

Hybrid Rescue: Il Futuro del Salvataggio in Mare

Scopri Hybrid Rescue, il primo catamarano di salvataggio ibrido che unisce la resistenza del polietilene e l'eleganza della vetroresina. Progettato per garantire sicurezza e durabilità, è lo strumento ideale per chi opera nel settore balneare e turistico.



Caratteristiche chiave:

- **Scafi realizzati in polietilene ad alta densità.** Schiumatura in poliuretano espanso all'interno, che assicura la galleggiabilità anche in caso di danneggiamento dello scafo.
- **Coperta in vetroresina di alta qualità,** lavorata a mano per un design elegante e una seduta confortevole.
- **Collegamenti in alluminio anodizzato:** massima resistenza alla corrosione.
- **Modulare e flessibile:** possibilità di sostituire i singoli scafi.
- **Completamente e facilmente smontabile per rimessaggio invernale.**

Mercati target:

- **Spiagge e stabilimenti balneari** che richiedono sicurezza e affidabilità.
- **Resort e strutture turistiche** che vogliono offrire soluzioni all'avanguardia per il soccorso in mare.

Scegli Hybrid Rescue e porta innovazione e sicurezza nelle tue attività!

Dimensioni 4535x1750x443 cm



CE

2  + 1  +  = 240 kg CAT. D





SAI VATAGGIO

Dinamico, sicuro e veloce
Dynamic, safe and fast



BAYLIFE

 Dinamico e veloce per il soccorso in mare; la forma degli scafi a chiglia piatta lo rende molto stabile anche in condizioni di mare critico. Fornito di ruote d'alaggio incorporate negli scafi, per velocizzare le operazioni di soccorso. Equipaggiato di serie di n° 2 salvagenti Solas, cime di lancio, Baywatch e mezzo marinaio. Materiale di costruzione: n° 3 traverse di collegamento scafi in acciaio inox, scalmiera in ottone, scafi e coperta in vetroresina rinforzata, riserva di galleggiamento in polistirolo.

 Fast and dynamic for rescue operations. The flat keel of the hull makes it very stable, even under the most difficult sea conditions. It has haulage wheels incorporated in the hull to speed up rescue operations. It is also equipped with 2 Solas ring lifebuoys, launch cables, a rescue can and a boat hook. Construction material: 3 hull connection beams in stainless steel, brass rowlocks, hulls and deck in reinforced fiberglass and a polystyrene reserve buoyancy.

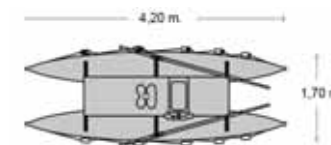



2  + 1  +  = 190 kg CAT. D

Mare mosso, nessun problema
Heavy seas, no problem



VIAREGGIO RESCUE

 Ideato dal sig. Barsanti Mario, noto artigiano e maestro d'ascia con lunga esperienza di bagnino di salvataggio sulle coste della Versilia dove spesso si affrontano condizioni di mare mosso, con venti di Libeccio o Maestrale. Il pattino di salvataggio Viareggio Rescue è stato progettato per poter affrontare questi mari, per poter dare soccorso immediato ai bagnanti in pericolo. È fornito di ruote d'alaggio incorporate negli scafi, ciò permette di partire da riva velocemente. Equipaggiato di serie con nr. 2 salvagenti anulari, sagola galleggiante da 30 m, mezzo marinaio e salvagente Baywatch. Realizzato in vetroresina, traverse in acciaio inox, scalmo in ottone, portascalmo con innesto a baionetta che permette di bloccare o sganciare rapidamente il remo.

 Designed by Mario Barsanti, a famous boat-builder with a long experience as a lifeguard on the Versilia coast, where strong north-westerly or south-westerly winds can create very rough sea. Viareggio Rescue rescue boat has been developed to be used in rough sea conditions, to provide immediate help to people in danger in water. The boat has launching wheels built into the twin hulls, making it easier to leave quickly the shore. Standard equipment includes 2 ring lifebuoys, 30 m of floating lifeline, a boathook and 1 lifeguard rescue can. Made of fiberglass with stainless steel crosspieces. Brass rowlock and rowlock support with bayonet type attachment enabling the oar to be rapidly secured or released. Reserve buoyancy.

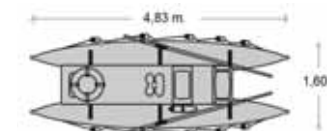

CE 3  +  = 240 kg CAT. D



TORRETTA LIFEGUARD COLOMBO

Lunghezza 120 cm - Larghezza 120 cm
Altezza con tetto 440 cm
Altezza postazione 200 cm
Supporti aggiuntivi per interro: 60 cm

Completamente in acciaio inox con
pannelli e tetto in vetroresina.

Completamente smontabile.

Possibilità di utilizzare i tre pannelli per
sponsorizzazioni pubblicitarie.





VIAREGGIO RELAX

Invito al relax

Invitation to relax



762



352



072



868



899





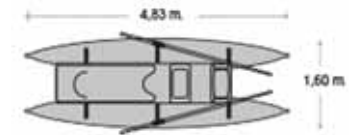



145







CE 3  +  = 240 kg CAT. D

PARADISE

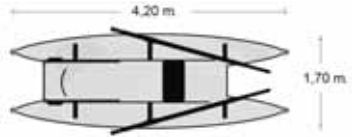

- | | | |
|---|--|--|
| 
762 | 
352 | 
072 |
| 
868 | 
899 | 
145 |

CE 

2  + 1  +  = 190 kg CAT. D

Comfort e stile
Comfort and style



GRETA

 La spiaggia Greta, ha un design essenziale, moderno ed elegante; ideale per piscine e per il mare. Permette di abbronzarsi sul bagnasciuga lambiti dalle onde nelle ore più calde e di proseguire l'abbronzatura in due posizioni di cui una con le gambe più in alto del tronco per migliorare la circolazione e per catturare anche gli ultimi raggi del sole della giornata. È indistruttibile, non teme la salsedine; maneggevole e leggera da portare; per l'alloggiamento invernale non avrà problemi di spazio: è sovrapponibile. Greta è costruita in polietilene lineare ad alta densità.

 With its essential, modern and elegant design, Greta is the ultimate sunbed for any swimming pool or for the sea. You can sunbathe lapped by sea waves enjoying even the hottest sun. One position allows you to keep your legs high, improving your circulation and catch even the latest sunrays of the day. Salt-water corrosion resistant, indestructible, handy and light to carry around. It can be stacked for an easy winter storage. Greta is manufactured in high-density, linear polyethylene.

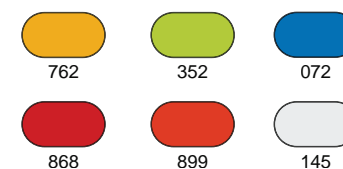



WEIGHT 14 kg
MATERIAL: POLYETHYLENE

L'evoluzione di comfort e stile
The evolution of comfort and style



GRETA EVO

 Ideale per prendere il sole, questa nuova spiaggina nasce dall'evoluzione della fortunata spiaggina Greta. È dedicata a chi non si accontenta, ancora più confortevole e stabile sia a riva e soprattutto nel galleggiamento in acqua dove si alza anche la linea di galleggiamento per un comfort davvero inimmaginabile grazie anche al suo disegno conformante al corpo.

 GRETA EVOLUTION is the evolution of our bestseller Greta. It is an ideal sunbed, even more comfortable and stable. It can be used on the shore and it is extra comfortable on water thanks to its improved floating capacity and its ergonomic shape.

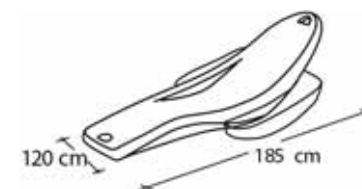
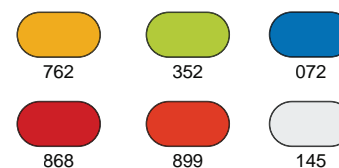

WEIGHT 18 kg
MATERIAL: POLYETHYLENE

MALIBU

 Malibu non si gonfia più, infatti è sempre pronto a regalare intense emozioni fatte di relax e divertimento.

Concepito per il noleggio, perciò pratico, leggero e con i suoi colori attira e si fa notare, solidamente galleggiante (fino a 120 kg). Gli utilizzatori possono addirittura agganciarsi insieme, con le apposite stringhe, per formare colorate piattaforme del divertimento in acqua. È l'attrazione dell'estate che non può mancare nei moderni centri balneari.

 Always ready for use, since it doesn't need to be inflated. With Malibu you can either have fun or relax. Ideally designed to be rented, eye – catching, handy and lightweight, Malibu can safely carry people weighing up to 120 kg. Moreover they can be hooked together using specific bands and form fun colorful platform on the water. Malibu is a must have for all the modern beach clubs and sea resorts.

Non si gonfia più

Relax! No matter if alone ore all together

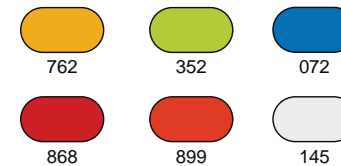

WEIGHT 14 kg
MATERIAL: POLYETHYLENE



SUP, il nuovo gusto dell'avventura per "surfare" o prendere il sole.
Ideal for leisure activities and sports



NIRVANA

 SUP, il nuovo gusto dell'avventura per "surfare" o prendere il sole.
Dotata di due compartimenti stagni e rete elastica. Ideale per il tempo libero e lo sport.

 Ideal for leisure activities and sport. It is equipped with two watertight storage compartments and an elastic net.
Ideal for leisure activities and sports.

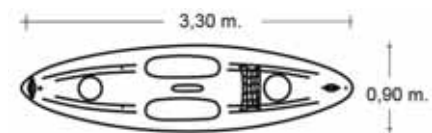

WEIGHT 22 kg
MATERIAL: POLYETHYLENE

Divertirsi da soli o in compagnia
Having fun on your own or with friends



AKITA

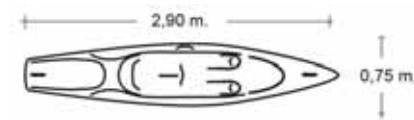
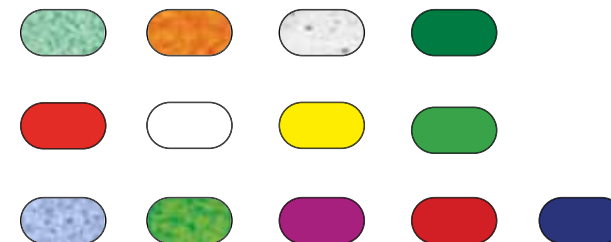

COCKPIT 120 x 48
WEIGHT 20 kg
MATERIAL: POLYETHYLENE

Divertirsi da soli o in compagnia
Having fun on your own or with friends



AKITA DOUBLE

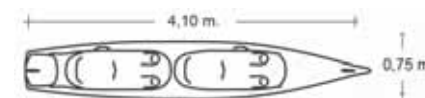
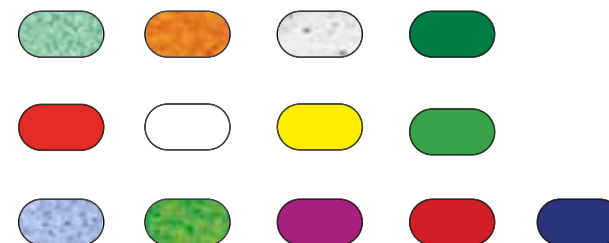

COCKPIT 120 x 48
WEIGHT 28 kg
MATERIAL: POLYETHYLENE



PEGASO K1

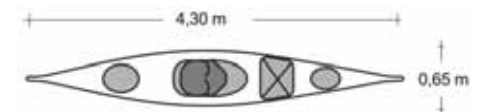
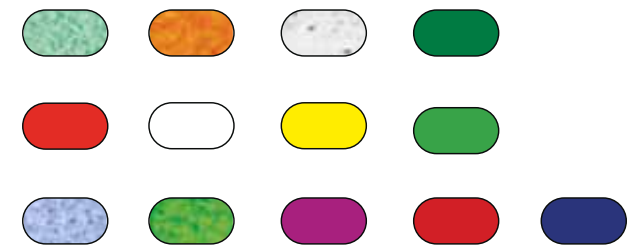

COCKPIT 86 x 48 - VOLUME 3701
 WEIGHT 20 kg
 MATERIAL: POLYETHYLENE

MOOREA 123

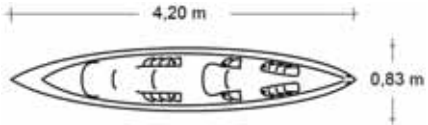
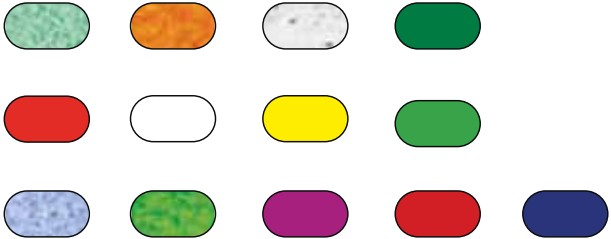

WEIGHT 34 kg
MATERIAL: POLYETHYLENE

ACCESSORI CANOE E RESCUE

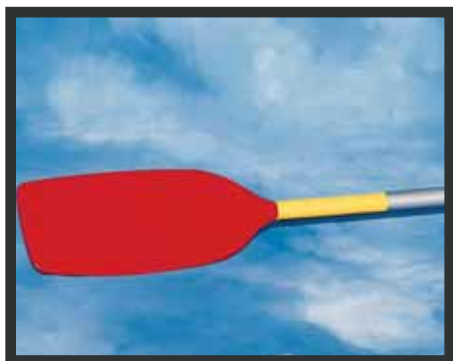

C13



C14



C15



C16



C17



C18

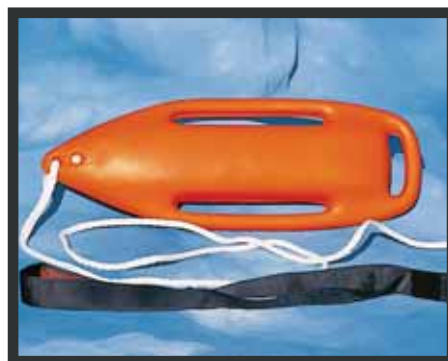

C19



C20



C21



C22

PEDAL BOATS SPARE PARTS

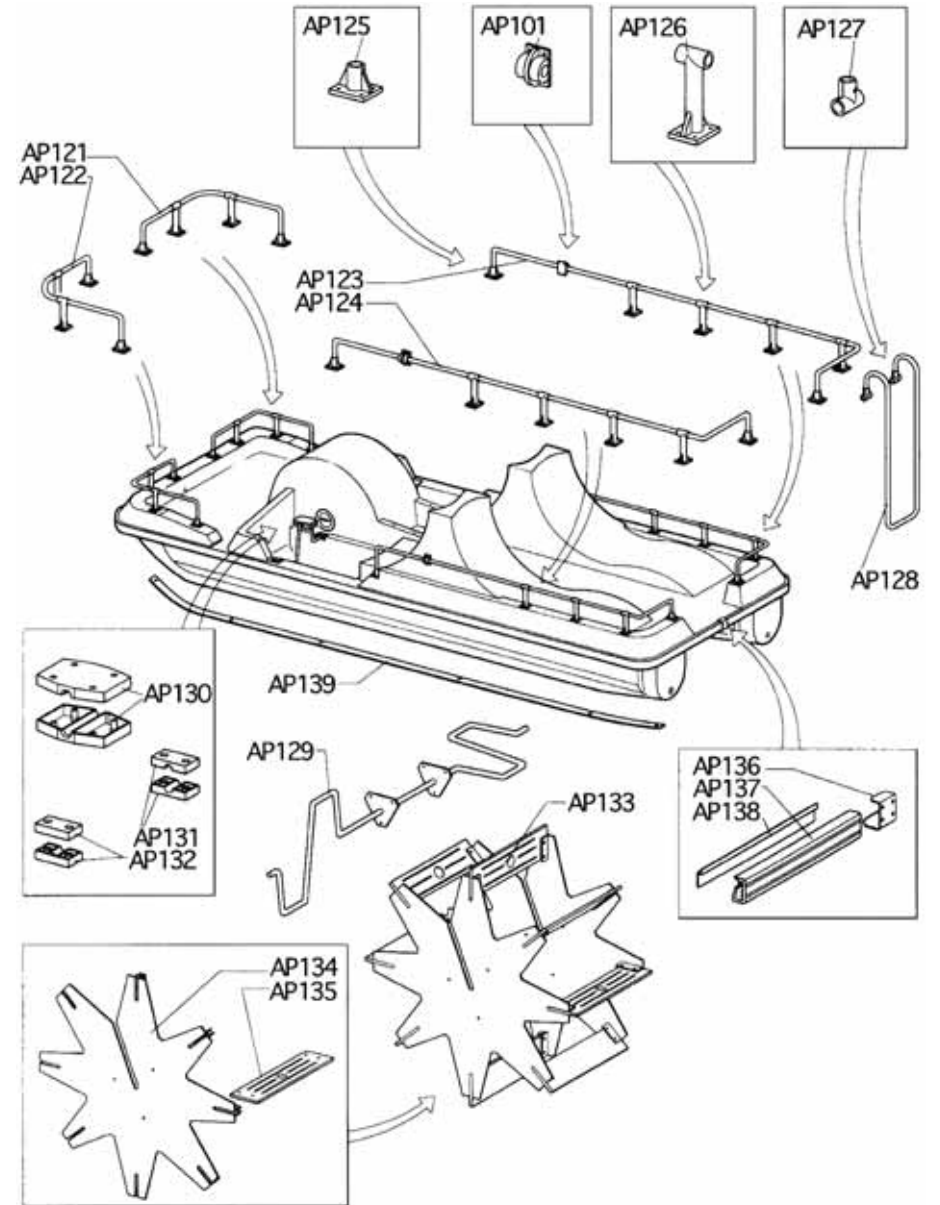
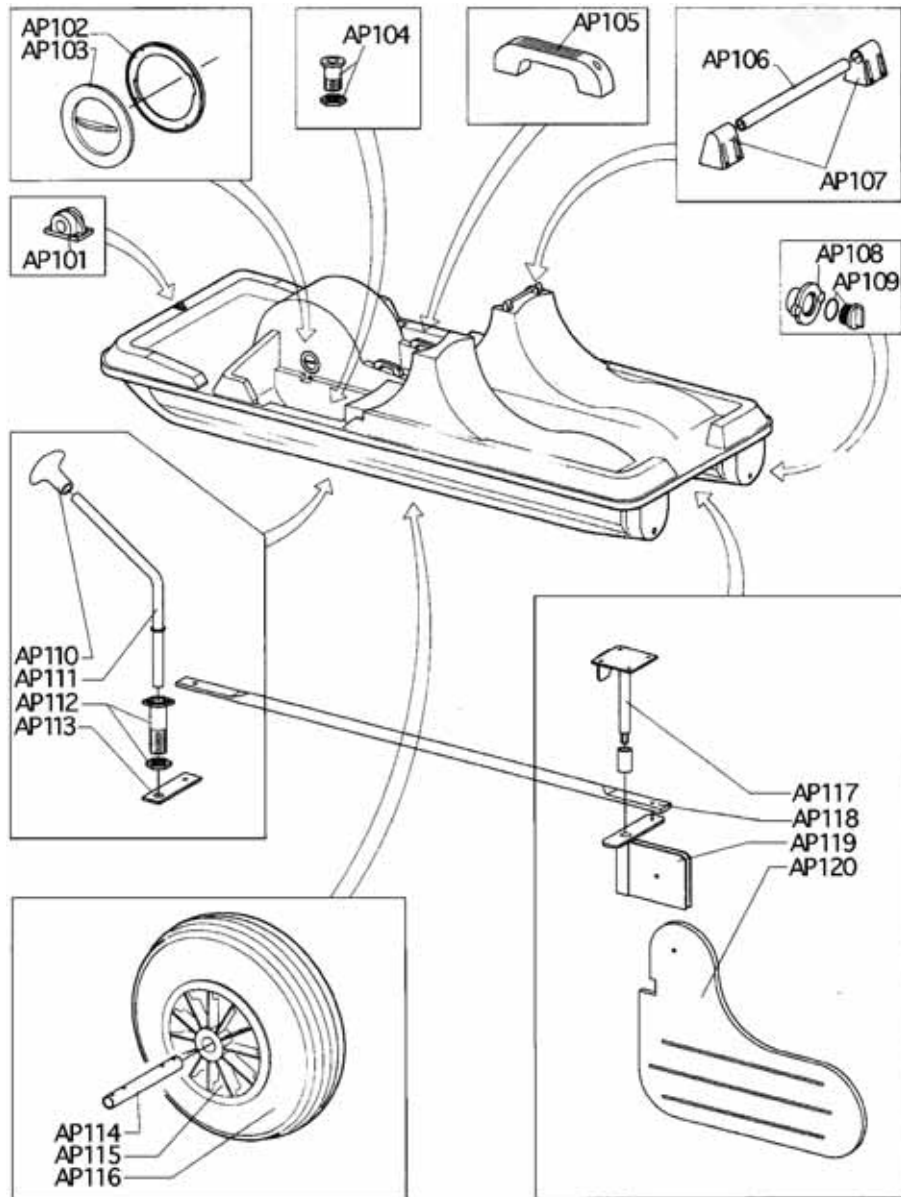

COLORI PER FIBRA DI VETRO

COLORS FOR FIBERGLASS

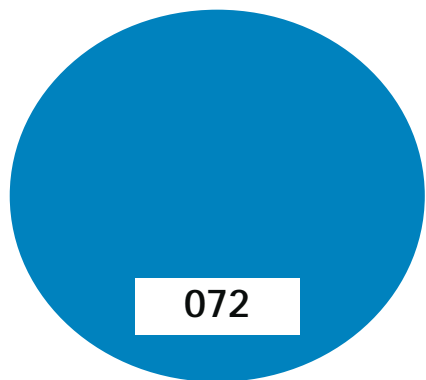

RAL 5012

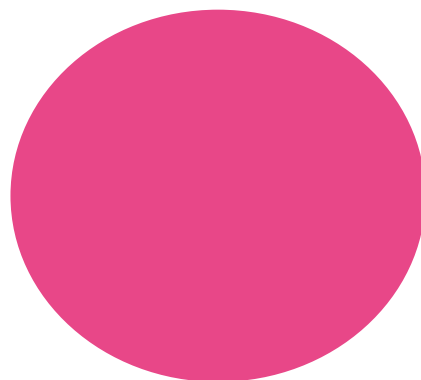

RAL 4003

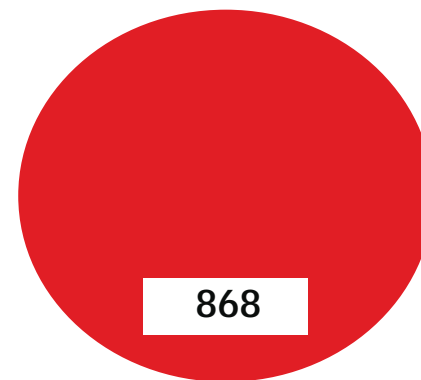

RAL 3020

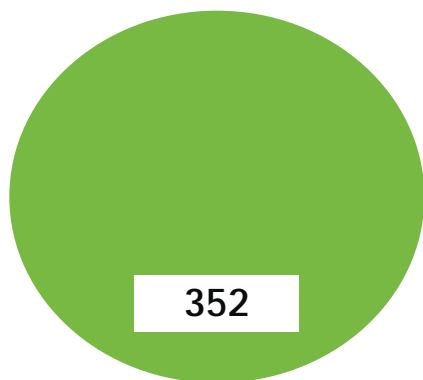

PANTONE 375 C

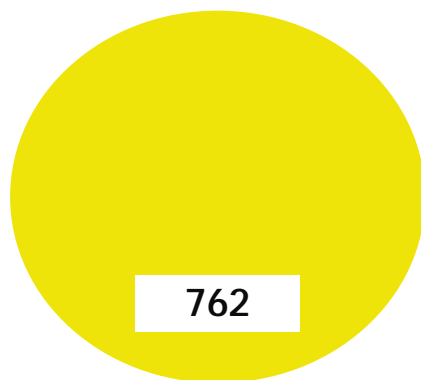

RAL 1018

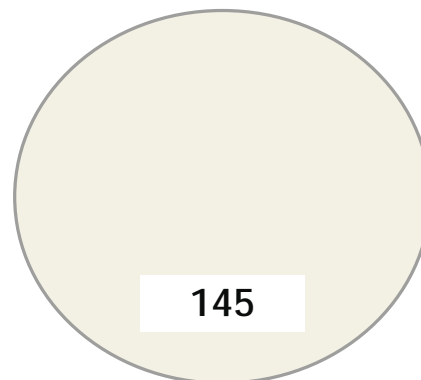

RAL 9010

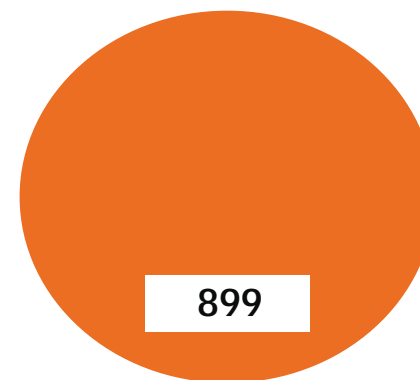

RAL 2004

COLORI PER POLIETILENE

COLORS FOR POLYETHYLENE







MARTINI Costruzioni Nautiche s.r.l.

AREA MARIS d.o.o.

Trg Kralja Tomislava, 7 - 52100 Pula
Tel. +385 52 382 393 - Fax +385 52 382 394

e-mail: info@areamaris.hr

www.areamaris.hr